

We form your ideas
in Plasterboard

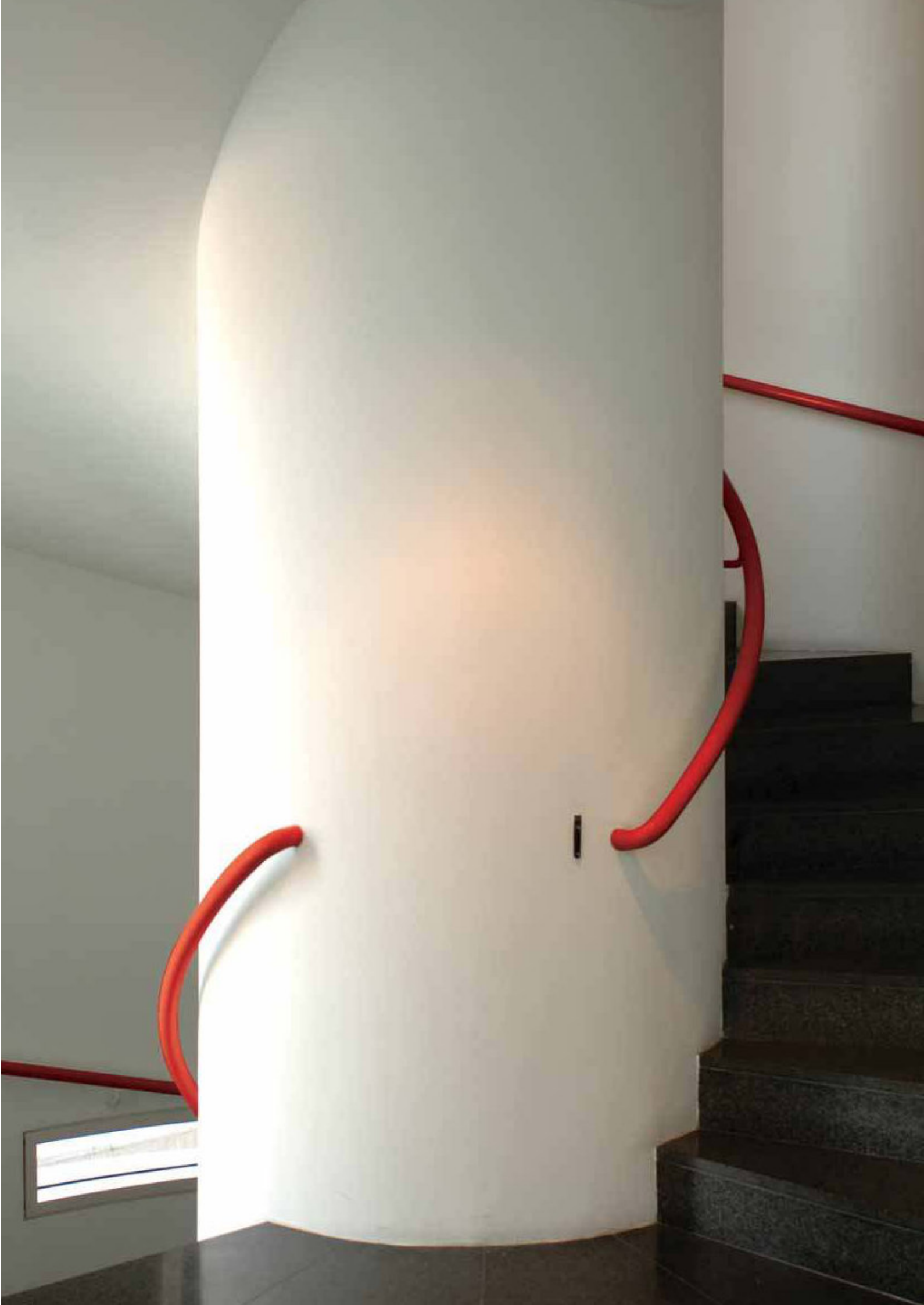





We Form Your Ideas in Plasterboard

V-Cut offers an exciting opportunity to economically pre-manufacture plasterboard profiles to suit your design ideas.



▼ Typical ceiling application showing recess features and bulkheads.

The process involves cutting grooves into the plasterboard so that it then simply folds to the required shape.

This allows easy, quick and high quality installation. The grooves can be anything from straight to V cuts and even curves are possible.

V-Cut Ltd offers architects, designers, contractors and clients the possibility to use this tried and tested solution. The only constraint is the designer's imagination.

Whether it is simple L shaped profiles for window reveals or complex stepped profiles for bulkheads, V-Cut can create quickly the design requirements without the need for expensive moulded sections or expensive on site labour.

Off site manufacture means faster on site performance.

Our CNC machinery achieves tight and precise tolerances such that anything delivered by us reflects exactly your design requirements to the highest possible quality.

V-Cut profiles provide the best possible quality finish whilst saving money by reducing expensive supporting structure and by allowing a quick and easy installation.





V-Cut plasterboard profiles not only offer interesting high quality design solutions but they are cheap to produce and provide the designer and contractor many advantages over the alternative solutions.

In most projects plasterboard angles are traditionally produced by cutting boards on site and then fixing the pieces to either a metal or wood framework. The profile then has to be taped and jointed involving the installation of trimming beads. V-Cut plasterboard profiles come in one piece and are therefore faster to install, cheaper and safer than on site cutting. The many benefits are set out below.

- ▼ Fantastic design opportunities with multiple and tight folding possibilities
- ▼ Precise manufacture to the customer's requirements
- ▼ Higher quality with clean and sharp edges for finished walls and ceilings
- ▼ Increase in productivity with faster installation than cutting and trimming boards
- ▼ High stability and strength
- ▼ No extensive labour work through easy installation
- ▼ No cutting of boards on site
- ▼ No corner/trimming beads required
- ▼ Reduced jointing on site
- ▼ Reduced requirements for framing
- ▼ More economical than moulded profiles
- ▼ Easier to repair than beaded constructions
- ▼ Less waste with a reduction of on site dust
- ▼ Off site manufacture
- ▼ Profiles can be supplied flat packed or preformed



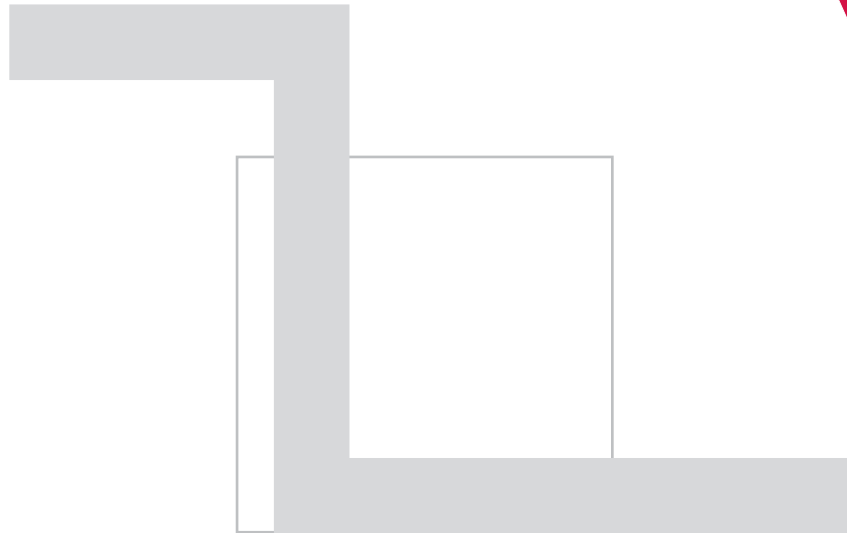

L Shape V-Cut Profiles



The position of the V-Cut can be adjusted to suit the needs of the design and eliminate the need to cut and trim boards on site.

Standard straight ninety degree L shaped profiles have many applications and are simple to produce by the V-Cut process.

The position of the V-cut can be adjusted to suit the design required. The L Shape is easy to manufacture and as a standard product is available for instant delivery.

Typical applications include:

- ▼ Door reveals on partitions and dry lining
- ▼ Window reveals on dry lining
- ▼ Single bulkheads, upstands and downstands in ceilings
- ▼ Light troughs for concealed lighting arrangements
- ▼ Corners to partition walls

U Shape V-Cut Profiles



U shaped profiles with a standard ninety degree angle are as simple as L shapes to produce by the V-Cut process.

The standard range includes U shaped profiles for various thicknesses of plasterboard walls.

However, the position of the V-Cut can be adjusted to any size or angle depending on the needs of the project and the design. The resulting profile eliminates the need to cut and trim boards on site.

The U shape is easy to manufacture and as a standard product is available for instant delivery.

Typical applications include:

- ▼ Door reveals for partitions and dry lining
- ▼ Free openings in partitions
- ▼ Floating end caps to partitions
- ▼ Beam encasements
- ▼ Light troughs and concealed lighting arrangements
- ▼ Services encasements

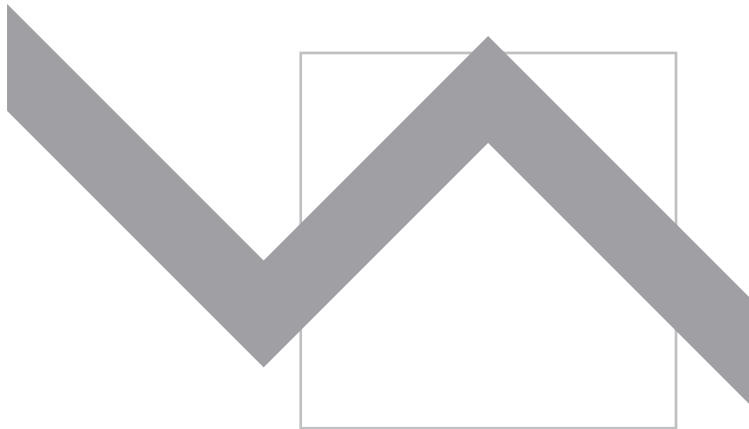

Z Shape V-Cut Profiles



Even Z Shaped profiles are included in our standard range and can be delivered preformed or flat packed.

With sides formed at ninety degrees to each other, the Z shaped profile offers endless design possibilities, whether for bulkheads in ceilings or features in walls. Pre-manufactured V-Cut profiles allow easy and quick installation and save expensive and complicated framework on site.

The Z shape is easy to manufacture and as a standard product is available for instant delivery.

Typical applications include:

- ▼ Door reveals on partitions and dry lining
- ▼ Corner profiles to walls
- ▼ Changes in wall thicknesses
- ▼ Beam encasements
- ▼ Bulkheads in ceilings
- ▼ Services encasements

Curved V-Cut Profiles



Our modern manufacturing equipment has the facility to cut not just V grooves but also slots into the plasterboard. This enables the manufacture of curved on section profiles such as round column casings, curved ceiling bulkheads, curved walls/linings or rounded end caps for partition walls.

When pre glued in the factory, the curved casing is strong and requires minimal framing for installation.

It is not just pre-made simple folding or curved profiles which open up the many possibilities for achieving economical design solutions. In addition, whether it is a cut to size service or a complex requirement such as machining openings, apertures or ventilation slots into the boards, our equipment has multiple capabilities to achieve the desired results.

The possible applications of V-Cut plasterboard are endless.



▼ Typical ceiling application showing curved bulkheads.

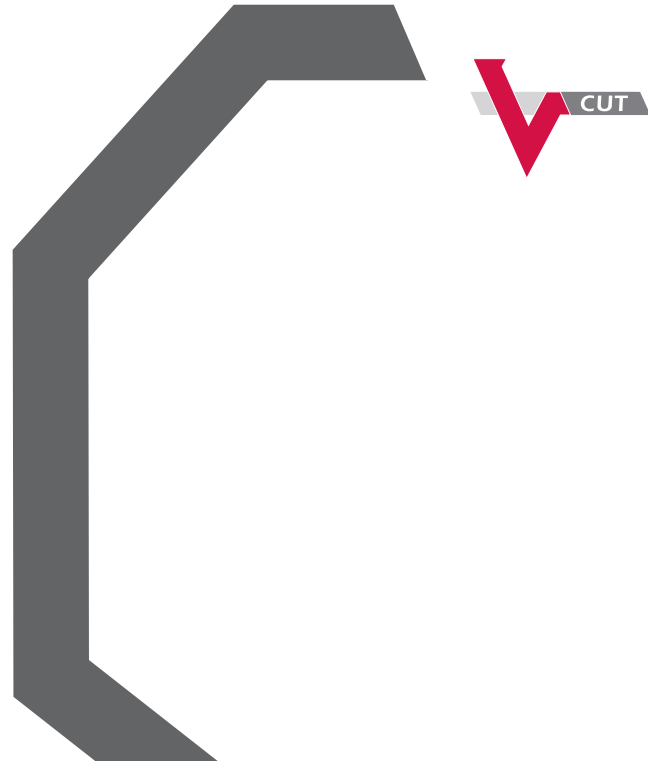

Complex V-Cut Profiles



Combined technical knowhow, gluing and other processes generate even greater possibilities for intricate, unusual features and details in walls and ceilings such as multiple stepped profiles.



The V-Cut process opens up a whole new variety of possibilities for unique solutions. Complex design no longer means complicated installation. This applies not just to plasterboard ceilings, dry lined walls and partitions but also to other applications such as cable or pipe encasements. Indeed, the product has great flexibility in its application not just to solutions for new or refurbishment construction projects but also to other industries, e.g. exhibitions stands, where fast installation is a must.

By gluing the V-Cut sections in the factory the profiles can be supplied to site ready for immediate installation. The resulting profile is strong with the added benefit of requiring reduced support framework.

The technique of gluing can be applied to all the standard profiles as well as curved, on plan, L and U shapes to achieve curving bulkheads or ceiling features such as light troughs. These curved profiles would normally have to be engineered as moulded sections which involve longer lead in periods and mould costs.

The V-Cut process has neither of these disadvantages and permits complete plasterboard rather than mix and match solutions.



Environmental Advantages

The need for environmental responsibility in the selection and use of materials is increasing in order to minimise damage to the earth's ecosystem.

The supply and use of buildings has potentially a greater impact on the global environment than any other human activity. Also construction is a major contributor to waste sent to land fill sites. Choosing natural materials from sustainable abundant or renewable sources which contain no harmful contaminants to man's health is ever more critical as is minimising the potential for waste.

Environmentally Friendly

V-Cut profiles are manufactured from plasterboard made from either natural gypsum, one of earth's most common natural minerals; or synthetic gypsum from, e.g., flue gas desulphurisation of power station emissions. The base material can actually be 100% manufactured from industrial by products with the paper faces coming most exclusively from recycled paper.

▼ **Health & Safety** V-Cut plasterboard profiles have no known adverse health effects and are not classified as hazardous to man's health under UK legislation as well as helping to reduce inconvenient "wet" processes on site.

▼ **Reducing Waste** V-Cut plasterboard profiles are prefabricated and therefore minimise the extent of dust generated from cutting boards on sites which may irritate eyes, sensitive skin or the respiratory system. With careful design at the appropriate stage, waste can be "designed" out, thereby, reducing the potential for harm to the environment and man.

▼ **Recycle** Recent legislation has focused on the need to reduce the amount of plasterboard waste sent to land fill sites. As a consequence schemes have been developed in a number of countries to recycle plasterboard. V-Cut plasterboard profiles reduce waste from cutting boards on site, the dust created during manufacture is collected along with the miscellaneous off cuts and sent for recycling or can be used as a fertiliser.





Technical Details

No corner beads – no jointing – no cutting on site – easy to install – easy to repair.

If you use V-Cut profiles for standard or simple details such as window reveals or corners on partitions, you will immediately recognise the benefits.

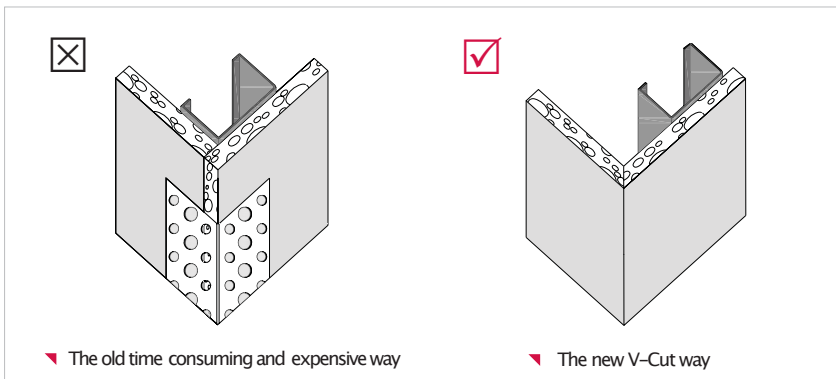

The pre manufactured profile is strong and the excellent quality cannot be achieved by cutting and skimming boards on site.

Standard details are now easy to install and the benefits and possibilities are endless. Just think about how much time and money you could save.

Also complex design details can be pre manufactured and benefit from the V-Cut high quality and money saving possibilities.

Complex profiles such as light covers no longer mean expensive solutions. There is no need for moulded or expensive site built constructions anymore. V-Cut makes these difficult profiles easy and simple.

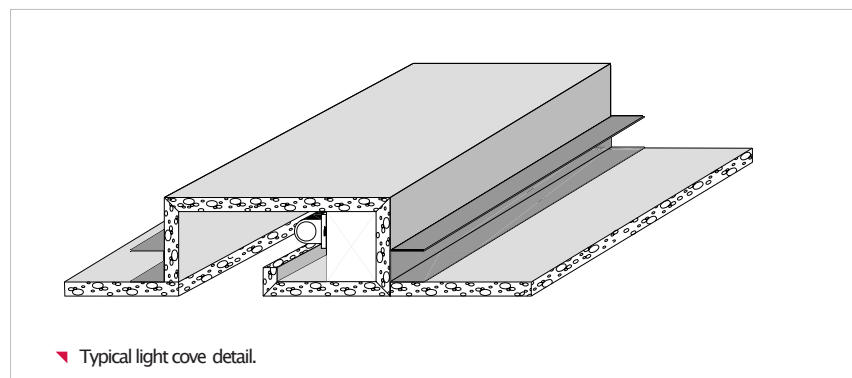



Requirement	Permissible	Comment
Folding boards	<input checked="" type="checkbox"/>	Paper faced boards only – straight
Cut/machined boards	<input checked="" type="checkbox"/>	All types. L/U shaped boards to curve supplied either preglued or in parts
Board thicknesses	up to 25mm	
Standard boards	<input checked="" type="checkbox"/>	
Fire resistant boards	<input checked="" type="checkbox"/>	Follow manufacturer's printed literature for achieving specific fire rating requirement
Sound resistant boards	<input checked="" type="checkbox"/>	Follow manufacturer's printed literature for achieving specific sound rating requirement
Moisture resistant boards	<input checked="" type="checkbox"/>	
Vapour boards	<input type="checkbox"/>	Request technical support
Impact resistant boards	<input checked="" type="checkbox"/>	Follow manufacturer's printed literature for achieving specific impact resistance requirement
Thermal insulation boards	<input type="checkbox"/>	Request technical support
Pre-perforated boards	<input type="checkbox"/>	Not recommended for V cutting
Square edged	<input checked="" type="checkbox"/>	
Tapered edged	<input checked="" type="checkbox"/>	
Rounded edged	<input checked="" type="checkbox"/>	
Installation conditions		Follow board manufacturer's printed literature
Machining accuracy		1/10th of a millimetre
Maximum board width	1250mm	
Maximum board length	3000mm	
Final finish requirements		For tape and joint, skim or decoration – follow board manufacturer's printed literature

This brochure illustrates a number of standard solutions. However, V-Cutplasterboard profiles have many more applications and we welcome the opportunity to discuss your individual and bespoke solutions.



Standard profiles

Product code	Board	Thickness	Length	Dim a	Dim b	Dim c
L1/St	Standard	12.5	2400	100	100	n/a
L2/St	Standard	12.5	2400	200	200	n/a
L3/St	Standard	12.5	2400	300	300	n/a
L4/St	Standard	12.5	2400	100	598	n/a
L5/St	Standard	12.5	2400	200	598	n/a
L6/St	Standard	12.5	2400	300	598	n/a
L7/St	Standard	12.5	2000	100	100	n/a
L8/St	Standard	12.5	2000	200	200	n/a
L9/St	Standard	12.5	2000	300	300	n/a
L10/St	Standard	12.5	2000	100	598	n/a
L11/St	Standard	12.5	2000	200	598	n/a
L12/St	Standard	12.5	2000	300	598	n/a
U1/St	Standard	12.5	2400	100	100	100
U2/St	Standard	12.5	2400	200	200	200
U3/St	Standard	12.5	2400	300	300	300
U4/St	Standard	12.5	2400	100	398	100
U5/St	Standard	12.5	2400	200	198	200
U6/St	Standard	12.5	2400	199	200	199
U7/St	Standard	12.5	2000	100	100	100
U8/St	Standard	12.5	2000	200	200	200
U9/St	Standard	12.5	2000	300	300	300
U10/St	Standard	12.5	2000	100	398	100
U11/St	Standard	12.5	2000	200	198	200
U12/St	Standard	12.5	2000	199	200	199

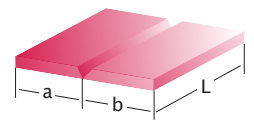

L shape

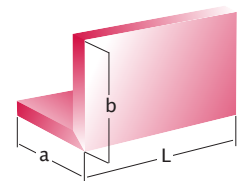

L shape

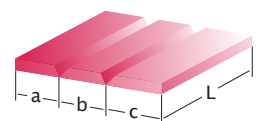

U shape



Z shape

For moisture resistant board substitute MR after the Ln/Un code, for sound resistant substitute SR, for fire resistant FR, e.g. L1/FR.



V-Cut Ltd
Unit 8 Dundas Close
Portsmouth
PO3 5RB

tel: +44(0) 20 3092 1377

email: enquiry@vcut.co.uk
www.vcut.co.uk